

## iBS03 Specification

### iBS03 Waterproof Sensor Beacon

iBS03 is an IP67 waterproof BLE beacon with different sensor options. The BLE is a very low power 2.4G radio that can transmit the beacon information efficiently. The typical beacon battery life is 4 year in default settings. iBS03 is a rugged design for working in tough conditions.



### Features

#### General

- ARM Cortex™-M3 32-bit processor
- Support BLE 4.2 and BLE 5 long range
- IP67 waterproof
- 2M of drop protection
- Powered with 1XCR2450 battery
- Long battery life: 4 year in typical beacon setting
- Android APP for configuration
- Panic/alarm button
- Power on/off switch(internal)
- Sensor activity wake up mechanism to save power
- Size: 43mmx43mmx14.8mm
- Operating temperature: -20°C to 75°C
- Certificate: CE/FCC/IC/TELEC/NCC.

#### Sensor

- Hall sensor with magnet to detect open/close event
- Temperature/Humidity sensor for environment monitoring (**iBS03T add humidity sensor from SN:2006...**)
- Accelerometer for motion detection or activity monitoring

#### RF

- 2.4GHz frequency band
- Maximum transmit power +5dB
- Receiver sensitivity: -97 dBm @1Mbps, 0.1% BER
- On board PCB antenna
- >100M range in open space

### Applications

- Beacon for location tracking
- Sensor network
- Building automation
- Health and wellness monitoring
- Activity monitoring
- Security
- Smart home
- Access management
- Advertisement
- Industrial automation

### Block Diagram

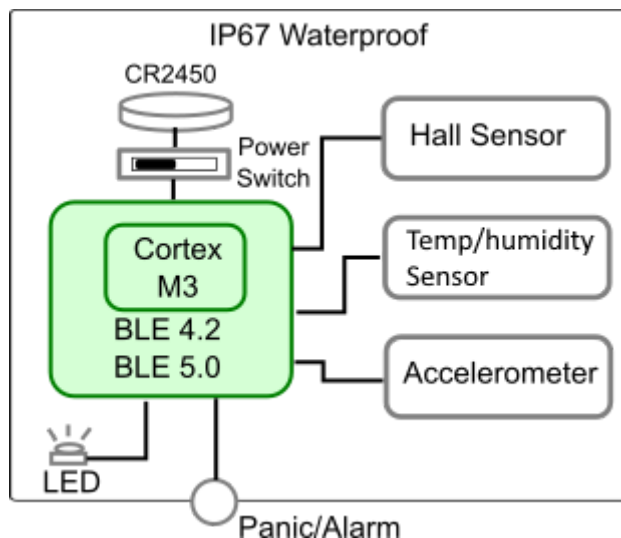

# INGICS TECHNOLOGY

## Models

Model Name	Description	Advertising interval	Note
iBS03	Basic beacon for tracking the position of people or assets. (a Hall sensor is built in for open/close detection)	User configurable from 100ms~1 min. Default: 5 s	Sensor status change( magnet moving closer or moving away) will trigger a series of transmit to inform the status change
iBS03T	Beacon with temperature/ humidity sensor for environment monitoring	User configurable from 100ms~1 min. Default: 5 s Sensor updated at 0.5X (advertising interval), min.10s	
iBS03G	Beacon with accelerometer for motion event detection, including the fall detection.	User configurable from 100ms~1 min. Default: 5 s	Sensor status change( still->motion, motion ->still, or falling) will trigger a series of transmit to inform the status change.
iBS03RG	Beacon with accelerometer for activity monitoring	Not configurable. Fixed at 300 ms	Every 300 ms, it will broadcast 3 records of accelerometer value(one record in 100ms). Each record has an x,y,z axis acceleration value.

## Typical Usage

1. Beacon is always broadcasting messages including status and sensor data. Users can use APP to receive the message. We also have the beacon gateway iGS01S(WiFi) or iGS02E(Ethernet) that can be used as a receiver.



2. Use iGS01S or iGS02E beacon gateway to receive the beacon message and send it to cloud server. Users can access and manage the data anytime, anywhere.

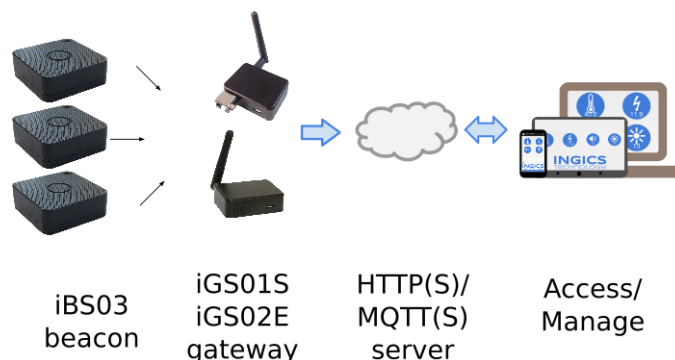

## Specification

# INGICS TECHNOLOGY

## Absolute Maximum Rating

Supply Power	CR2450 battery
Storage Temperature	-40° to 85° Celsius

## Recommendable Operation Condition

Operating Temperature	-20° to <b>75°</b> Celsius
Humidity	Max 95%, Non condensing, relative humidity
VDD	+3V by CR2450 battery
IP67	30min.@1 Meter water

## Average Current Consumption

iBS03 (120 times/day of sensor active event)	12.43uA*, in default 5s transmit period. 17.2uA*, in 10s transmit period@125Kbps(long range).
iBS03T	12.38uA*, in default 5s transmit period 16.0uA*, in 10s transmit period@125Kbps(long range).
iBS03G (120 times/day of sensor active event)	16.13uA*, in default 5s transmit period. 20.9uA*, in 10s transmit period@125Kbps(long range).
iBS03RG	Average: 117.68uA*, in default 300ms transmit period w/ power saving (working at 12H/day)

\* Measured with Panasonic CR2450 battery.

## Battery Life Simulation

iBS03	4.4 yr*, in default 5s transmit period@1Mbps. 3.2 yr*, in 10s transmit period@125Kbps(long range).
iBS03T	4.4 yr*, in default 5s transmit period@1Mbps. 3.4 yr*, in 10s transmit period@125Kbps(long range).
iBS03G	3.4 yr*, in default 5s transmit period@1Mbps. 2.6 yr*, in 10s transmit period@125Kbps(long range).
iBS03RG	6.4 month**, in default transmit period and power saving (working at 12H/day).

\* Calculated with one CR2450 battery with 600mAH capacity. Considering the battery discharge characteristic, only 80% of capacity is used for calculation. This value is just for reference and may be varied with component tolerance and different environments.

\*\* w/ power saving mode, the iBS03RG will stop advertising the G-value when the value is not changed for a certain time. When the value changes over the threshold, it will start to advertise again.

## Hall Sensor Characteristic

Operation point	Typ : 1.8mT( N or S)
Release point	Typ : 1.1mT( N or S)
Hysteresis width	Typ: 0.7mT( N or S)

## Humidity/Temperature Sensor Characteristic

# INGICS TECHNOLOGY

Humidity accuracy	0-80%RH: Typ +2%, max +-3% 80-100%RH: Typ +3%, max +-4.5%
Response time	Typ : 18 s, at 1m/s airflow
Drift	Typ : 0.05 %RH/°C
Long term stability	Typ : <=0.25 %RH/yr
Temperature accuracy	Sensor: Typ. : +-0.22 °C, Max: +-0.32 °C Whole unit: TBC
Response time	Typ. : TBC
Long term stability	Typ. : <=0.01 °C/yr

## Accelerometer Characteristic

Acceleration range	+2G, +4G(default), +8G, +16G
Sensitivity	+2G: 4mg/digit +4G: 8mg/digit +8G: 16mg/digit +16G: 32mg/digit
Offset Accuracy	+40mg

## BLE RF Specification

Transmit Power	Max.: +5dBm
RSSI Accuracy	+/- 4 dB@1Mbps
Receiver Sensibility	-97 dBm @1Mbps, 0.1 %BER -103dB @125Kbps, 0.1 %BER
Maximum Received Signal	+4dBm @1Mbps, 0.1 %BER >+5dBm @125Kbps, 0.1 %BER
Frequency band	2.400 – 2.483 GHz
Frequency Deviation	+350 kHz @1Mbps, -260~310KHz @125Kbps
Antenna	on board PCB antenna
Range	>100M in open space(BLE 4.2)

## Dimension

Dimensions L x W x H (mm)	43 x 43 x 14.8
Weight(g)	24

## Package

One package box(size: 12.7cmX6.1cmx6.9cm) contains 10 units of iBS03, 10 pc of double side tape, and 20pc of stainless screw .

10X



## Revision History

DATE	REVISION	CHANGES
Sep 17, 2018	0a	Initial release
Oct 22, 2018	0b	Fix power consumption value and battery life simulation
Jun 4, 2019	0c	<ol style="list-style-type: none"><li>1. Change packing box size and more detail in package</li><li>2. Modify RF distance with verified value</li><li>3. Support ble 4.2 and ble 5 long range</li></ol>
Dec 12, 2019	01	<ol style="list-style-type: none"><li>1. Wording fix</li><li>2. Add regulation statement</li></ol>
Jul 28, 2020	01a	iBS03T add humidity sensor from SN:2006... So add humidity sensor spec
Sep 11, 2020	01b	Enhanced operation temperature from 70°C to 75°C
Sep 24, 2020	01c	<ol style="list-style-type: none"><li>1. Update block diagram with BLE 5 and temp/humidity sensor</li><li>2. Typical battery life changed from 7 year to 4 year(7 year is calculated at 0dB and 10 sec transmit period)</li><li>3. Update BLE RF specification table with more BLE5 long range parameters</li><li>4. Add BLE 5 long range current consumption and battery life estimation</li></ol>

## Statement

### Federal Communication Commission Interference Statement

This equipment has been tested and found to comply with the limits for a Class B digital device, pursuant to Part 15 of the FCC Rules. These limits are designed to provide reasonable protection against harmful interference in a residential installation. This equipment generates, uses and can radiate radio frequency energy and, if not installed and used in accordance with the instructions, may cause harmful interference to radio communications. However, there is no guarantee that interference will not occur in a particular installation. If this equipment does cause harmful interference to radio or television reception, which can be determined by turning the equipment off and on, the user is encouraged to try to correct the interference by one of the following measures: . Reorient or relocate the receiving antenna. . Increase the separation between the equipment and receiver. . Connect the equipment into an outlet on a circuit different from that to which the receiver is connected. . Consult the dealer or an experienced radio/TV technician for help.

**FCC Caution:** To assure continued compliance, any changes or modifications not expressly approved by the party responsible for compliance could void the user's authority to operate this equipment. (Example - use only shielded interface cables when connecting to computer or peripheral devices).

**FCC Radiation Exposure Statement** This equipment complies with FCC RF radiation exposure limits set forth for an uncontrolled environment. This equipment should be installed and operated with a minimum distance of 20 centimeters between the radiator and your body.

This transmitter must not be co-located or operating in conjunction with any other antenna or transmitter. The antennas used for this transmitter must be installed to provide a separation distance of at least 20 cm from all persons and must not be co-located or operating in conjunction with any other antenna or transmitter.

This device complies with Part 15 of the FCC Rules. Operation is subject to the following two conditions: (1) This device may not cause harmful interference, and (2) This device must accept any interference received, including interference that may cause undesired operation.

### Industry Canada Statement

This device complies with Industry Canada licence-exempt RSS standard. Operation is subject to the following two conditions: (1) this device may not cause interference, and (2) this device must accept any interference, including interference that may cause undesired operation of the device.

Le présent appareil est conforme aux CNR d'Industrie Canada applicables aux appareils radio exempts de licence. L'exploitation est autorisée aux deux conditions suivantes : (1) l'appareil ne doit pas produire de brouillage, et (2) l'utilisateur de l'appareil doit accepter tout brouillage radioélectrique subi, même si le brouillage est susceptible d'en compromettre le fonctionnement.

### IC Radiation Exposure Statement

This equipment complies with IC RSS-102 radiation exposure limit set forth for an uncontrolled environment. This equipment should be installed and operated with minimum distance 20cm between the radiator and your body.

Cet équipement est conforme aux CNR-102 d'Industrie Canada. Cet équipement doit être installé et utilisé avec une distance minimale de 20 centimètres entre le radiateur et votre corps. Cet émetteur ne doit pas être co-localisées ou opérant en conjonction avec autre antenne ou émetteur. Les antennes utilisées pour cet émetteur doivent être installés et fournir une distance de séparation d'au moins 20 centimètre de toute personne et doit pas être co-située ni fonctionner en conjonction avec une autre antenne ou émetteur.

## NCC 警語

### 第十二條

經型式認證合格之低功率射頻電機，非經許可，公司、商號或使用者均不得擅自變更頻率、加大功率或變更原設計之特性及功能。

### 第十四條

低功率射頻電機之使用不得影響飛航安全及干擾合法通信；經發現有干擾現象時，應立即停用，並改善至無干擾時方得繼續使用。

前項合法通信，指依電信法規定作業之無線電通信。

低功率射頻電機須忍受合法通信或工業、科學及醫療用電波輻射性電機設備之干擾

## DECLARATION OF CONFORMITY

EU EU RED - DIRECTIVE 2014/53/EU -

This Declaration that the following designated product

**Sensor Beacon**  
**Model No.: iBS03**  
**Multi-listing Model No.: iBS03, iBS03T, iBS03G**  
**Brand Name: INGICS**

.....  
(Product identification)

complies with the essential requirements of the **EU RED - DIRECTIVE 2014/53/EU** on the approximation of the laws of the Member States relating to **Radio Spectrum Matters**.

Assessment of compliance of the product with the requirements relating to radio spectrum matters was based on Annex IV of the Directive **2014/53/EU** and the following standard:

EMC	Radio Spectrum	Safety
EN 301 489 -1: V 2.2.0 (2017)	EN 300 328 (V 2.1.1, 2016-11)	EN 60950-1:2006+A11:2009
EN 301 489 - 17: V 3.2.0 (2017)	EN 62479 : 2010	+A1:2010+A12:2011+A2:2013
	EN 50663 : 2017	

.....  
(Identification of regulations / standards)

This declaration is issued for  
**INGICS TECHNOLOGY.**  
**2F., No.15-2, Changshou St.,**  
**Shulin Dist., New Taipei City 238,, Taiwan, R.O.C.**

.....  
(Name / Address)

Furthermore we declare that our product will be produce in correspondence with all requirements according to the Directive **2014/53/EU** .

Name: J.K.Fan

Title: President

Signature 

Date: 2019. 8.5